

Assembly Instructions

Nesting Tables - Set of 3

Parts List

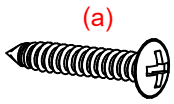

X24

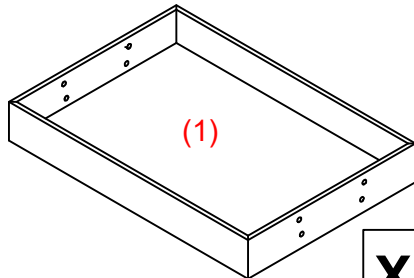

X3

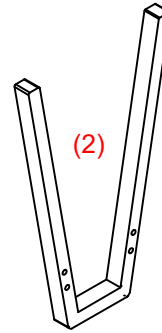

X6

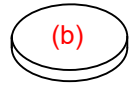

X12

Step1

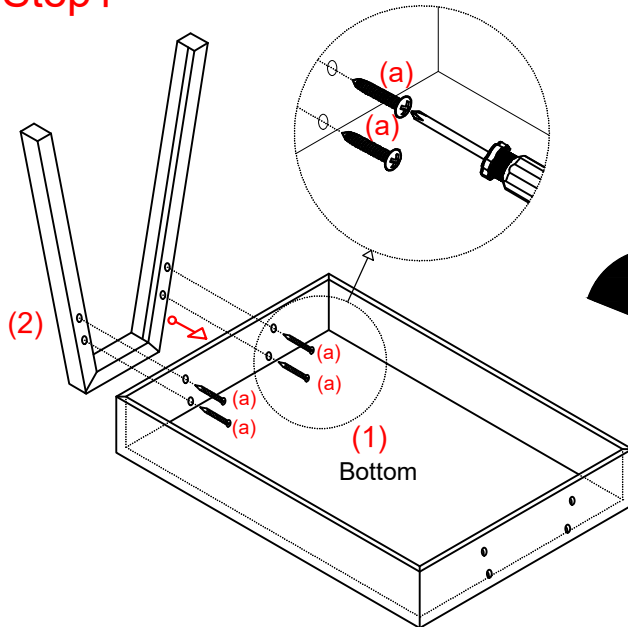

Step2

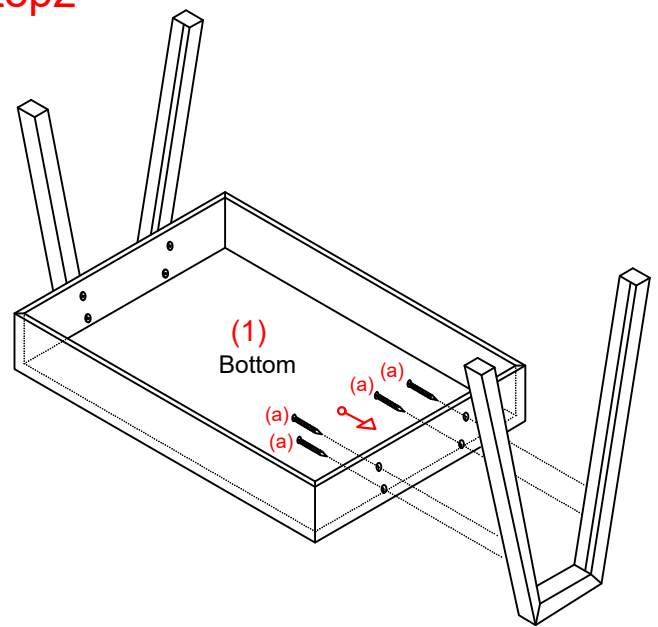

Step1: Position the trays on flat surface.

- (a) Attach the tray to the legs with the mounting screws to the pre-drill holes marked on the tray after balancing.

Note: Do not tighten the screws completely.

Step2: Repeat the previous steps with all table trays

- (b) install the felt pads on the bottoms of legs to prevent slipping and scratches on the floor.

- Repeat the previous steps with all table trays

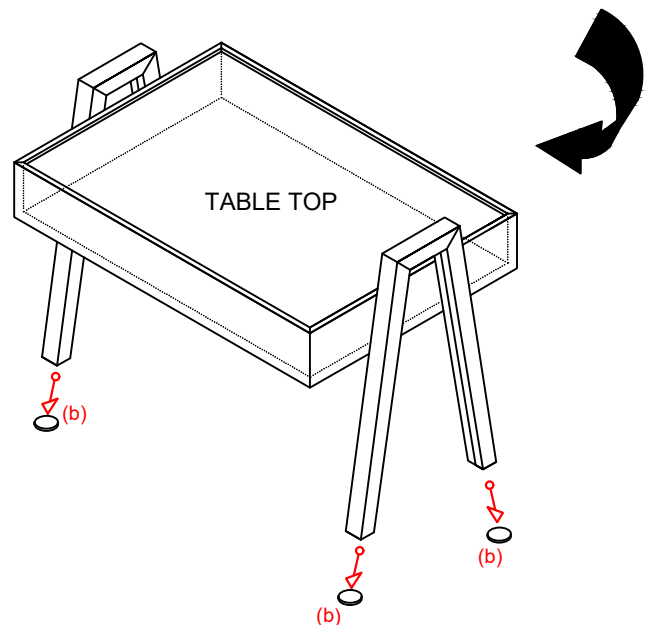

Assembly is completed